

School Board agrees not to pursue bond now

From page 13

Taking into account the current economic conditions, we feel that this is not the time to pursue this project. We want to make it clear that we are not abandoning our beliefs; we just don't feel the timing is right to get this bond passed. In the meantime, the board will begin putting together contingency plans that will address the district's response to emergency

situations in our buildings should they arise."

Members of the Facilities Committee will be meeting in the near future to discuss ideas and form plans for any emergencies that may occur. They will be devising plans to ensure the safety of students and staff in case of roof leaks, earthquakes, or other major disasters.

While talking about deteriorating

conditions of the aged portable classrooms at the junior high, it was determined that there are empty classrooms available in the high school, due to last year's staff budgeting cuts. Creative cost-cutting measures are a priority with this school board.

The next school board meeting will be Monday, September 12, at 7:00 p.m., in the district board room.

PTO asks for help supplying math books to Banks school

From page 13

state-wide. Banks School District received considerably less funding this year than last year. In addition, the district is also facing declining enrollment, which determines how much the state allocates to the district. For the 2011-2012 school

year, \$1.5 million in cuts are required collectively from the Elementary, Jr. High and High Schools. Banks SD is focusing the budget on keeping teachers and keeping class sizes down as much as possible, and maintaining current programs. Based on this information, the Banks School District is unable to allocate any budget towards textbooks for the foreseeable future.

It has become apparent to the Banks Elementary School PTO that responsibility for funding new textbooks rests on our shoulders as parents and concerned citizens.

To address this issue, the PTO has implemented a Textbook Adoption Fundraising Committee. The purpose of this committee is to raise money toward a new K-6 Math curriculum. The cost of one of these curriculums is upward of \$60,000-\$120,000 depending on the length and quality of the curriculum chosen and the amount of funds we are able to raise. The committee is actively applying for grants from local foundations and corporations and is also asking local businesses to help. The goal this year is to raise \$60,000 through grants, business donations and parent contributions. In addition to fundraising, the committee is sending out a letter to our representatives with a petition asking that funding be reinstated to the education system. You can read and sign this letter at the Banks Elementary Back-To-School Barbeque on September 15th.

As parents and concerned citizens, you are invited to support this mission in any way you can. You may donate online through paypal at lilbravesp.to.blogspot.com. To make a pledge or for more information, contact BanksElementaryPTO@gmail.com or Solina Krickovich, BES PTO Fundraising Coordinator at 503-324-3830. Please share with any family, friends, and business owners who may want to donate to this cause. Thank You from Banks Elementary School PTO - "Joining Hands to Support Our Children's Future".

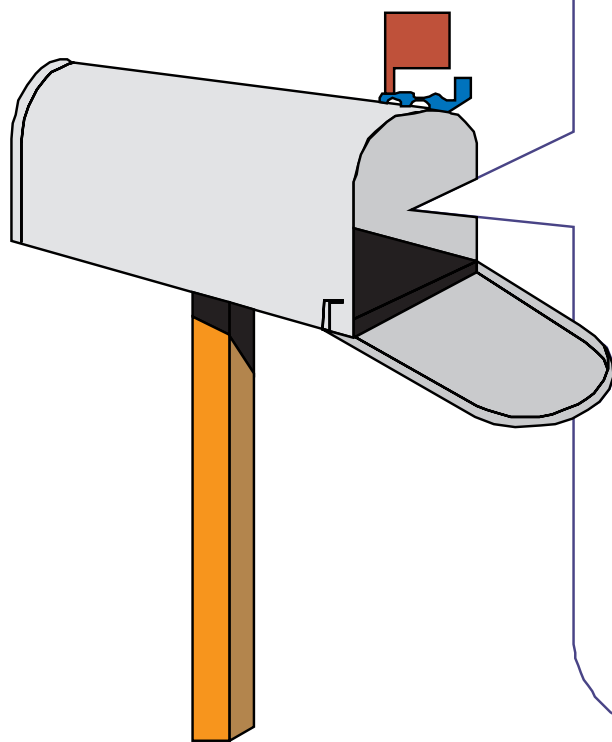

Want to know what happens around here all year? Get

The Independent

delivered to your home for a year for only \$20.00

Call today to start your subscription

503-429-9410