

# County gives information on CZ Trail

Since the completion of the CZ Trail Mitigation Report by Parametrix, Inc. in September, 2008, Columbia County Road Department has made significant progress in addressing property owner conflicts along the Scappoose end of the CZ Trail. The Parametrix Mitigation Report identified specific concerns of residents that included loss of privacy, and trespass issues by trail users.

In December, 2009, the Columbia County Road Department received a grant of \$108,315 from the Oregon Parks & Recreation Department for mitigation work to address residents' concerns

along the trail. A mitigation implementation plan was adopted by the Board of County Commissioners in February, 2010, which provided a detailed description of the mitigation measures to be taken, their placement and eligibility criteria for those residents requesting mitigation along the trail.

Currently, security and visibility screening is underway for seven of the estimated 16 affected property owners. Fencing has been the predominant measure chosen by property owners participating thus far, with expenditures to date at \$45,299.

It is expected that the mitiga-

tion efforts for all residents identified in the Parametrix study will be completed by December 2010.

Other improvements to the trail included in the grant and currently being completed, include:

- Bollards at trail/road crossings between Multnomah Channel and the trail near B&B Market. Installation of additional bollards will continue into the Chapman area this fall. Expense to date is \$4,300 for purchase and installation of the bollards

- Signage will be placed this winter as a result of the development of a sign placement plan, which will serve as a guide for installation. Those signs are in process of being manufactured.

## Bits & Bites

By Jacqueline Ramsay



I'll start with a sad note.

My hanging zucchini has croaked. Why? Who knows. I think the root strangled itself – too much weight on the main stem – anyhow no zucchini bread this fall for the Golden Oldies. Sorry – Boo Hoo.

I read in the paper that the School Board is fed up – I agree – liquor has it's place and it should be off and out of an "in town" camping site. I just wonder how the ban will affect next year's crowd?

I went to the County Fair this past week – my granddaughter showed her pig, Nero. She did pretty good. Now it's gone to market and she's "off" pork for awhile. The calf (a baby) got 1st place – Grand Champion – in its class.

I've been blackberry picking for about six weeks. Now it's time to jam and jelly, make pies and freeze fresh for winter – yum yum.

Well, it's hot again. Gee, nothing new there.

Oh, I just woke up. Hi, McMinnville.

I'm getting things lined up for my Fall schedule. I'll be busy again Monday 9-12, Tues. 10:45-2:45, Wed. 9-3, Thurs, 10:45-2:45, Fri, Gee Whiz, Sat. 9:45-2:45. I haven't got time to wonder what to do next.

See you folks on Wednesdays, I hope, at the Senior Center.

## 24 Years Ago This Month

The September 25, 1986, issue of *The Independent* included the following news story on the front page:

A joint meeting of the Vernonia City Council and Planning Commission on September 3 resulted in agreement on the content of a home occupations ordinance, as well as clarification of definitions, and some changes in the city's ordinance regulating fences.

When the changes are adopted, the height limitation for a front fence will be increased from three to four feet if the fencing material provides a "clear vision" such as chain link. Fences or hedges which obstruct view will remain at the 3' height limitation. The definition of "front fence" was clarified as being from the front edge of the structure to the lot line on the street of address.

Regulation of garage sales was discussed, with a consensus that three per year at any single address should be the limit, but no specific action was taken.

Planning Commission Chair-

man Jim Tierney also requested that copies of the city's Comprehensive Plan, and the Attorney General's Public Records and Meeting Manual be provided for each planning commission member. The council agreed that the information should be made available.

Following the joint session, the planning commission held their regular meeting and three public hearings.

A request for variance in the fence height limitation was requested by Debbie Elliott in order to build an 8' fence in her back yard. A public hearing was set to consider Elliott's request.

At the public hearings the commission granted requests for variance to Marvin E. Meyers to build a 4' chain link fence for Phyllis Wood on Riverside Drive; to Dirk and Noni Andersen for a two foot encroachment on the setback from the back lot line of their property on State Avenue; and to Richard and Cammie Waddell to open a business on Bridge Street without offstreet parking.

**"To give anything less than your best, is to sacrifice the gift."~ Steve Prefontaine**

**The gift is life. Do your VERY best.**



Lee Anne Krause, Future Director for the The Pampered Chef  
leeannekrause@gmail.com  
503-816-9810



www.pamperedchef.biz/leeannekrause

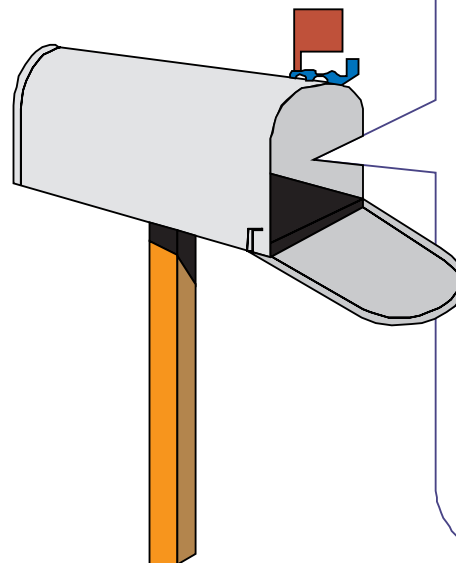

**Want to know what happens around here all year? Get**  
**The Independent**  
**delivered to your home for a year for only \$20.00**  
**Call today to start your subscription**  
**503-429-9410**