

# N. Plains seeks memorabilia for centennial party

One hundred years ago this September, a plat naming streets and boundaries for the new town of North Plains was filed with Washington County. The plat was approved and officially recorded by the county on October 1, 1910.

As the 100th anniversary of that date approaches, the North Plains Historical Society is assisting the City of North Plains in planning an October 2nd Centennial Celebration, which will commemorate not only the approval of the town

plat, but also the coming of the train.

In preparation for the event, the historical society is collecting stories, old photographs and other memorabilia from the early years of the Town of North Plains and the surrounding areas to share at the celebration.

The historical society would love to hear from people who rode the train to the North Plains area from any of the stops along the line – Lincoln, Connell, Groveland, Helvetia, Rock Creek, Burlington, Lin-

nton, and Portland to the east; Dersham, Christie, Wilkesboro, Banks, Timber and Tillamook to the west.

North Plains got its start at the expense of Glencoe, the formerly thriving community just to its northeast, and one of the first established villages in the Pacific Northwest. After the railroad bypassed Glencoe for a more direct route to Banks, most of its buildings and businesses moved up the hill to the newly formed town.

Current plans for the October 2nd celebration include an opening ceremony at 10:00 a.m. with speeches by local dignitaries; time capsule burial; old-time games with prizes; guided tours of historical sites of the area; an exhibit of Antique Powerland's early engines and machines; horse-and-wagon rides; special one-time commemorative USPS postmark cancellation, Centen-

nial historical displays; talks by local historian Jim Long and members of pioneer families of the area; live music and dancing; and—to cap off the day—a big fireworks show with Pumpkin Ridge in the background. This first official fireworks display by the City of North Plains will start at 7:45.p.m. Everyone is invited to join in the day's festivities.

If you know anyone who may have stories, scrapbooks, or photographs? Please contact us about any contributions or suggestions you may have. And please help us spread the word as we prepare for the celebratory events. Contact Jim Long at 503-647-0021, or PO Box 33 North Plains, Ore 97133-0033, or bluepgs@yahoo.com. The other contacts are Ruth and Carmen Pasley at 503-647-2367 or Crpasley@aol.com.

## Written entries sought by July 12

Oregonians who have something to say about humor, happiness, and joy, especially as they pertain to American history, culture, values, and identity, are invited to submit an essay or article for Oregon Humanities magazine's fall 2010 issue on the theme "Ha!" Oregon Humanities magazine, a triannual publication, is published by Oregon Humanities (formerly Oregon Council for the Humanities).

Submit a proposal or draft by July 12, 2010, to Kathleen Holt, Editor, Oregon Humanities magazine, 813 SW Alder Street, Suite 702, Portland, OR 97205, or k.holt@oregonhumanities.org. Please visit oregonhumanities.org to review the guidelines, download the complete call for submissions, and familiarize yourself with the publication. No phone calls, please.

Oregon Humanities magazine welcomes all forms of nonfiction writing, including scholarly essays, personal essays, and journalistic articles. We accept proposals and drafts of scholarly and journalistic features, which range between 2,500 and 4,000 words in length. We accept drafts only of personal essays, which should consider larger thematic questions and run no longer than 2,000 words. We almost exclusively publish Oregon-based writers. All contributors receive an honorarium. Currently the magazine is distributed to more than 12,000 readers. Essays from Oregon Humanities have been reprinted in the Pushcart Prize anthology and the Utne Reader. An essay from a recent issue will be included in Best American Essays 2010.

More information about our programs and publications can be found at oregonhumanities.org. Oregon Humanities is an independent, nonprofit affiliate of the National Endowment for the Humanities and a partner of the Oregon Cultural Trust.

### Run with Extra Confidence with Chevron DELO 400™ PLUS MOTOR OIL

The name you trust for:

- Gasoline
- Diesel Fuel
- Oils • Solvents
- Additives • Greases

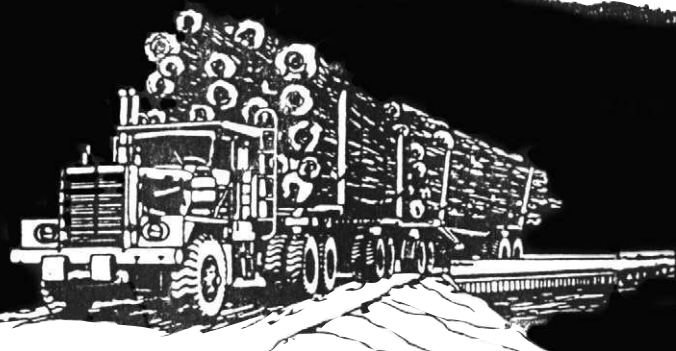
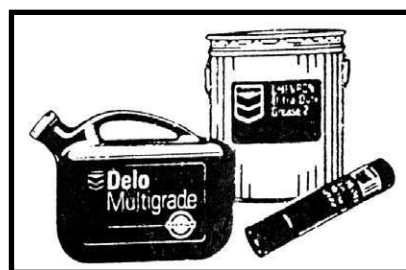

See us for...

### DECK OIL SHINGLE OIL

CALL

(503) 429-6606



## WILCOX & FLEGEL

720 Rose Avenue • Vernonia

### In the roller coaster ride of life, it is necessary to whoop, holler, scream and laugh... it's all part of life.



Lee Anne Krause, Future Director for the The Pampered Chef  
 leeannekrause@gmail.com  
 503-816-9810  
 www.pamperedchef.biz/leeannekrause

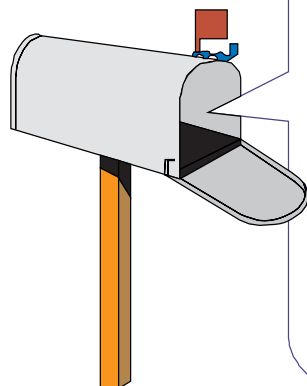

Want to know what happens around here all year? Get **The Independent** delivered to your home for a year for only \$20.00. Call today to start your subscription 503-429-9410

## Action Ads

INEXPENSIVE – EFFECTIVE

503-429-9410