



Left to right, Senator Betsy Johnson, Community Action Team (CAT) Deputy Director Jim Tierney and Adam Grzybicki from AT&T. See article at right. Picture courtesy of CAT.

AT&T grant for Vernonia needs

A grant of \$12,000 was donated by AT&T, March 30, to help relocate the Vernonia Senior Center, Vernonia Cares Food Bank and the Vernonia Health Clinic out of the path of future floods.

Accepting the check for Community Action Team (C.A.T.), grant administrator and program coordinator for the project, was Jim Tierney, C.A.T. Deputy Director,

Senator Betsy Johnson was instrumental in securing the grant and continues to play a strong role in Vernonia's recovery efforts, with her ongoing efforts to secure disaster assistance from the state and federal government on behalf of the City of Vernonia, the Vernonia School District 47J, residents, businesses and non-profits.

"We wish to thank AT&T for their commitment and support," Tierney said. "This tangible evidence of their recognition of the impact of the December 2007 flood truly helps keep our relocation efforts alive." Tierney continued, "It would have been impossible for us to make the progress we have made during the last two years without the support and guidance of Senator Johnson."

The AT&T funds were contributed specifically to provide pre-development assistance with the City of Vernonia's Rose Avenue Project, a mixed use project which will move these local non-profit organizations to safe ground provided to the City by the State of Oregon.

Over the next six months, the Rose Avenue Project will complete its design plan, and begin fundraising for construction. When complete, the project will move most of Vernonia's critical social services (the health clinic, food bank, senior center, electric co-op and other essential services) to safe ground above the flood plain.

Interested in community theater?

Everyone has a talent or two. Think about this for a minute and consider getting involved with a community theater in Vernonia.

Do you have a musical talent, dancing talent, acting/drama talent, carpentry or construction, lighting or staging, sewing or craftiness, artistic, teaching, writing ability, or other talent?

Those in the Vernonia community who are interested in having a Community Theater Production Company for youth of all ages are invited to attend an informal meeting on Thursday, April 15, at 6:00 p.m. at the Blue House. (Everyone is on

their own for food and drink.)

For questions, contact Mark Brown via email at mrmbrown@hotmail.com or Kinnell Steward at mtskys@verizon.net. Come see what community theater could look like with your involvement.

Library hosts a program, Apr. 6

Life in a Mega City: Images of Urban Bangladesh, will be a free presentation at the Vernonia Library on Tuesday, April 6, at 7:00 p.m.

Are there connections between our consumer choices and a global work force? What are the reasons for and challenges associated with the growth of mega cities such as Bangladesh, which is home to

See Library on page 10

Car wash helps school band

Get a clean car and help the Vernonia Schools Band Program at the same time.

There will be a car wash on the second Saturday of each month for six months (April 10, May 8, June 12, July 10, August 14, Sept. 11), from 11:00 a.m. to 3:00 p.m. in the District Office parking lot.

The Vernonia Middle and High School Bands want to wash your car. Donations would be appreciated.

Vernonia Senior Center News

Free hearing checks will be offered by a representative of Columbia Hearing Aids on the second Monday of each month, here at the Center; call for an appointment.

There's only one day left for the special half-price sale, but even without a sale, you will be delighted at the incredible bargains available in our Thrift Shop. It is open from 9:00 a.m. to 3:00 p.m.

Are you currently working on a quilt, crocheting an afghan, knitting a sweater, or other needlework project? If so, bring your project to the Senior Center on Tuesdays, any time from 10:30 a.m. to closing, and enjoy the company of others as you work.

The Center's Board of Directors meets on the second Friday of each month at 10 a.m. The meetings are open to members.

Lunch is served Monday through Friday at noon. A \$3.00 donation is suggested for those 60 and older, and \$4.00 for those under 60. If you prefer lunch to go, simply call ahead, 503-429-3912, and place your order for only \$4.00.

If you enjoy bingo you can have fun while you eat lunch. Diners play free Bingo each Monday starting at 11:45 a.m.

Breakfast is available Fridays at the Senior Center, from 7:30 to 9:00 a.m. at \$3.50 per person, regardless of age. Maple bars, made fresh daily, are \$1.00 each. If you want maple bars for a gathering of any kind, call 503-429-3912 a day or two ahead and place your order.

Everybody needs healthy feet to enjoy a firm foundation! Remember that Foot Care is scheduled on the second and fourth Fridays of each month, at \$15 per person. Call Marilyn Albro, R.N., for an appointment, at 503-429-0406.

Mary Poarch, from Providence Medical Center, will be here April 5 to discuss Medicare, from 12:30 to 1:30 p.m. Bring your questions with you.

Do you know someone who needs Meals on Wheels? If so, call Senior Information Assistance Representative Rosie McCoy at 503-429-3912. She will explain how to put this great service to work.

Vernonia Senior Citizens Center: 446 Bridge Street
Hours: Monday through Friday, 10 a.m. to 3:00 p.m.
Thrift Shop Hours: 9:00 a.m. to 3:00 p.m.
Phone: 503-429-3912

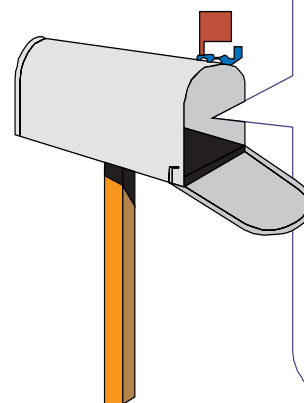

Want to know what happens around here all year? Get **The Independent** delivered to your home for a year for only **\$20.00**. Call today to start your subscription **503-429-9410**

*There are days for sunshine.
 There are days for rain. Cloudy days come and go.
 It is **STRENGTH** to smile through them all.*



Lee Anne Krause
 Independent Team Leader
 for the The Pampered Chef
 leeannekrause@gmail.com 503-816-9810
 www.pamperedchef.biz/leeannekrause

