

## 47J board gets kindergarten news

With both Ernie Smith and board chair Kim Wallace out sick, the Vernonia 47J Board of Directors took on a fairly light agenda at their April 9 meeting. The board unanimously authorized Superintendent Dr. Ken Cox to enter into a contract for project management services with whichever contractor is chosen from the applications solicited recently. The board also approved the appointment of Bill Langmaid to the Budget Committee.

In a somewhat convoluted arrangement, the board approved eliminating, from next year's general fund budget, half a Kindergarten teacher position and just over one classified Instructional Assistant position. The board had already been told that \$130,000 in Title I funds, plus \$90,000 in stimulus money, would be used instead of the general fund to pay for one

Kindergarten teacher and some special education services. With multiple funding streams, the district will still have two Kindergarten teachers, and expects to retain the same Kindergarten schedule as this year.

Dr. Cox announced that the amount of the bond to be sought for funding new schools will be announced at a school board workshop on April 30 at 6:00 p.m.

The grade school report to the board included the information that the Jump Rope for WGS PE Department raised \$1618.10. That amount will be matched by the Vernonia Community PTA and used to purchase a climbing wall for the new elementary school gymnasium.

The next regular board meeting will be May 14, starting at 6:00 p.m. in the District office.

## VHS announces 3rd qtr. Honor Roll

The following students were named to the Vernonia High School academic Honor Roll for the 2008-09 third quarter. Grade Point Averages (GPA) are on a scale of 1-4, with 4 equaling a perfect score.

Principal's Honors, 4.00 – Kaytee Burghard, Holly Cavett, Christopher Dass, Karly DeWitt, Laura Hein, Samantha Lee, Tricia Levenseller, Jackson Miller, Souvanny Miller, Gia The Nguyen, Chelsea Patton, Melissa Sandstrom, Kelly Smith, Natalie Wallace, and Nicholas Young.

High Honors, 3.50-3.99 – Jacob Alf, Christopher Bam-

burg, Bonnie Birkmaier, Jacob Bringman, Rachel Brown, Timothy Brown, Eric Budge, Joshua Butcher, Justin Caputo, Kaitlyn Carr, Crystal-Ann Carreon, Sarah Dupree, Adrienne East, Katie Ellington, Celine Feijoo, Joey Fergusson, Brandy Fosdick, Mackenzie Frantz, Brandon Gilbertson, Kristina Halvorson, Melissa Hermet, Calie Johnston, Keli Krieger, Alex Lende, Mickell Maller, Sarah Miller, Emily Mitchell, Nicole Mitchell, Ashley Paleck, Tasia Pond, Tim Prpich, William Ren, Amy Rethwill, Gavin Roberts, Mason

**See Honor roll on page 20**

## Student Clean Beaches Art Contest

Oregon fourth- and fifth-grade students are being invited to compete in the fourth annual Clean Beaches Art Contest.

The contest is open to fourth- and fifth-graders from all areas of the state. Deadline for entries is May 15.

The first place winner will receive a small prize and have his or her artwork posted on the Web site of the Oregon Beach Monitoring Program, the contest sponsor. The winning artist's teacher will receive a \$100 gift certificate to purchase

science and environmental education resources for use in the classroom. The prizes are paid for by the federally funded beach program.

"The goal is to raise awareness about the importance of protecting our beaches and ocean waters," said Jennifer Ketterman, beach monitoring program coordinator in the Oregon Department of Human Services. "There are things we can all do to help make sure they are healthy places to play and swim."

**See Beach art on page 20**

## Chalk Talk

*Chalk Talk is a monthly column of information about Vernonia schools. It is written by various staff members. This column was provided by Superintendent Dr. Ken Cox.*

Finally, we're making progress!

It seemed to take a long time for something to happen, but now that the Board has selected a site and an architectural firm, things are really heating up. The first group meeting with BOORA architects was held last Thursday. They reviewed with us the process and schedule that will lead to a design for our new schools over the next couple of months. In the meeting they went around the room for public input and, as a result, we discussed the idea of organizing the construction into smaller jobs so that local contractors would have a better chance of participating in the construction. We want our new schools to benefit the community in every way possible, even before they get built.

Throughout the design process, the architects will be seeking input from the community. Next Friday, April 17, they will be meeting with school staff from 1:45 to 5:00 p.m. to discuss the Strategic Education Plan (StEP) that was developed two years ago by the District and community members. The general public is also welcome to come and participate.

The following week we will be visiting some new schools, similar in size and design to what we will need, and then on Tuesday, April 28, all of the information that has been gathered

through these visits and the visitations made by our District Facilities Committee earlier in the year will be shared at a Town Hall Meeting beginning at 7:00 p.m. at the VMS Cafeteria. During this meeting the architects will also be seeking community input into the overall design and functionality of the school. We encourage everyone to come and share your ideas.

A description of the entire schedule of meetings with the architects is available on the district website through the 'New Schools BOORA Information' link on the Superintendent page. We will place copies of all meeting minutes and other information on the same page, as it becomes available. If you don't have internet access please just stop by the district office for a copy.

Our schools are the heart of our community! We want our new heart to be even more effective at serving the community than what we currently have. To do that we need to know what YOU want out of your schools, besides the best education for our children that we can provide. This is a unique opportunity for our community. A perhaps once-in-a-lifetime opportunity where your idea, or a comment you make, could become reality in our new schools, but it won't happen if you keep those ideas to yourself. Let's all get involved, work together, and make a difference! We are shaping the future for generations of Vernonia's children!

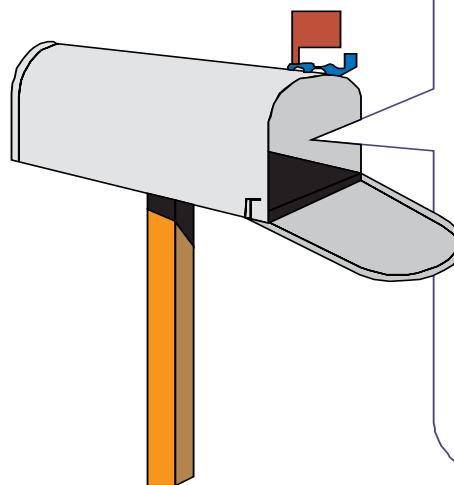
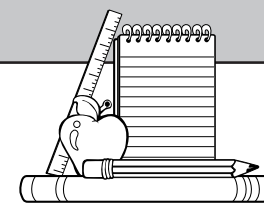

**Want to know what happens around here all year? Get**  
**The Independent**  
**delivered to your home for a year for only \$20.00**  
**Call today to start your subscription**  
**503-429-9410**