

Community

Help available with Medicare choices

If you have Medicare health insurance, you can switch to a different insurance plan until March 31. For example, if you have a Medicare Advantage plan offered by one insurance company, but you are not happy with the plan, you can switch to a different Advantage plan.

Columbia Co. SHIBA (Senior Health Insurance Benefits

Assistance) volunteers are holding a walk-in clinic for anyone with Medicare issues on Wednesday, March 11, at the Scappoose Senior Center, 11:30 a.m. to 1:30 p.m. No appointments are needed, you can just show up. Please bring paperwork showing your current coverage.

If you have a more complex

Medicare problem, call the Scappoose Senior Center at 503-543-2047 to have a SHIBA volunteer call you back.

SHIBA volunteers are trained by the state to help people with Medicare. They do not recommend particular programs, but help people sort through alternatives to find the best fit for their situation.

Looking for something "cool" to do?

Special Olympics Oregon hopes to raise \$100,000 this month in the first-ever Polar Plunge Columbia. At 11:00 a.m. on February 21, individuals and teams from throughout the Portland area – led by business leaders, celebrities and law enforcement – will make a mad dash into the river from the beach on NE Marine Drive. Proceeds from the event will go toward continuing the organization's mission: to deliver sports training and athletic competition to thousands of athletes in local communities state-wide during the winter, summer and fall sports seasons.

"Even in these challenging economic times, we're proud to say that we're still serving all of our athletes statewide, by offering them sports training and 37 local competitions year-round," said Margie Hunt, CEO of Special Olympics Oregon. "Events such as the Polar Plunge in

Portland, and a similar plunge in Bend help us tremendously in meeting the goals of our mission. We will continue to serve all those in Oregon – individuals and families – who are affected by intellectual disability. And we thank our dedicated volunteers and sponsors – firmly committed organizations such as Law Enforcement Torch Run and Mattress World – who are giving so selflessly to ensure that our events are successful and our mission is served."

Like its sister event, the Polar Plunge Deschutes, the first annual Polar Plunge Columbia has already touched the hearts of many who are taking part with unbridled passion and excitement.

Polar Plunge Columbia will take place on February 21, at Broughton Beach, Portland; on the south bank of the Columbia River, east of the intersection of

NE 33rd Avenue and Marine Drive. Registration begins at 8:30 a.m. – the plunge is at 11:00 a.m. The event is hosted by Law Enforcement Torch Run (LETR), a law enforcement-driven program for Special Olympics. Those interested in participating must raise a minimum of \$50.00 prior to plunge day in order to plunge.

Founded in 1972, Special Olympics Oregon is a year-round program offering Olympic-style sports to athletes with intellectual disabilities. Through Special Olympics, people with intellectual disabilities have the opportunity to be part of a worldwide sports movement. In sport, these athletes gain self-confidence, social competency and other enhanced skills, both physical and social.

Registration information and a full schedule of events can be found at www.soor.org.

Senior News

By Karen Miller, Senior Advocate
Community Action Team



News is good news so they say...but here's a few things:

Our Senior Police Academy is going well. We meet on Tuesdays at 3:00 p.m. Last week we discussed the what and hows of makings of drugs in and around town, and in your cabinets as well...

Call my office to sign up for our next AARP class; fees have gone up to \$14 or \$12 if you

are a member.

Seniors in need of legal aid advice? Call me to see if you qualify.

For our Senior Center members: Don't forget our birthday celebrations here are the last Friday of the month. Ice cream and cake at lunchtime and a free lunch for those celebrating a birthday during the month.

Between the snow and flu, we hope everyone is getting on the road to recovery.

Till next time.

INFORMATION NUMBERS

Senior Advocate...429-9112

Senior Center.....429-3912

Transportation.....429-4304

Think you can IMAGINE...GREEN?

See if you can you IMAGINE...GREEN with ideas that celebrate sustainable ideas to use, reuse, and recycle. It's an opportunity to share what you do to help the environment. Send your ideas to IMAGINE...GREEN, 725 Bridge St., Vernonia, OR 97064, or email to rebecca@the-independent.net.

Here's one IMAGINE...GREEN idea: Take lint from your dryer, mix with melted wax from candle ends, pour into the cups in a cardboard egg carton. When wax sets, tear apart for fire starters. This also works using sawdust mixed with melted wax.

*Home of
Northwest
Microbrews, Wines,
Sandwiches,
Coffees,
Smoothies
& More*



831 Bridge Street
Vernonia, Oregon
Open Daily
503-429-0214

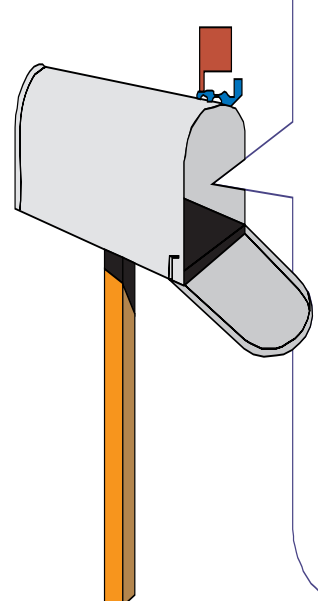

Want to know what happens around here all year? Get **The Independent** delivered to your home for a year for only **\$20.00** Call today to start your subscription **503-429-9410**

☆ GASOLINE ALLEY AUTO WRECKING ☆
503-429-7581
Most parts under warranty
Open Tuesday-Saturday 9:00 am to 4:00 pm
Closed Sunday and Monday
54372 Nehalem Hwy South, Vernonia, OR 97064
6 miles south of town on Hwy 47
Buying unwanted vehicles with clear title