

# RADIO

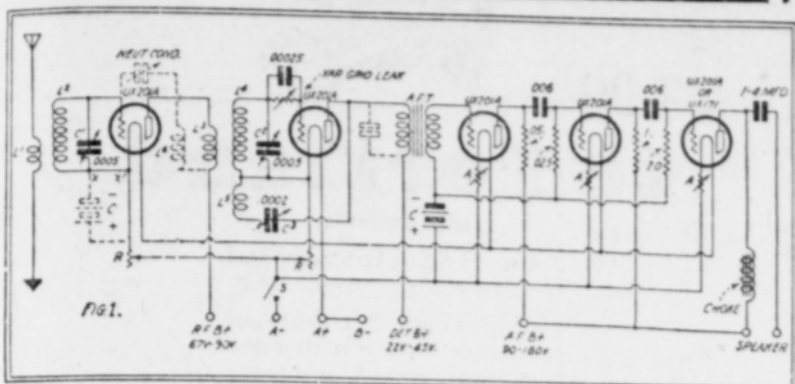

Diagram of the Selective Five-Tube Receiver Described in This Article. The Apparatus Indicated in Dotted Line is Optional.

By FRANK W. HARTH, In the New York Herald-Tribune.

There is nothing particularly new in this circuit, which is the old Weagant, with a few variations. The set originally was designed for local reception only, but one local did not come in very well, so a stage of radio-frequency was added. A location in the center of Manhattan was selected for a test.

The set is fairly compact, the panel being 7 by 21 inches and the baseboard 12 by 20 inches.

The chief claim of novelty is the placing of the R. F., secondary, and regenerative coils on one form and having them all of the same diameter. That simplifies the work somewhat.

There are five tubes, a R. F. amplifier, a detector and three audio amplifiers. The author selected the type of audio amplifier used because the transformer gives a strong initial input, free from distortion, for the two resistance-coupled stages to amplify. The result is a signal of surprising fidelity and somewhat greater volume than a two-stage transformer-coupled amplifier.

The coils are of the ribbed type of hard rubber tubing, recommended for high electrical efficiency. There are 12 ribs running lengthwise of the tube and spaced equally around the circumference. The turns of wire, touching only the tops of the ribs, leave a space under the coils and provide practically an air core. The antenna coil was wound (as shown in Fig. 2) with No. 22 D. C. C. wire, 15 turns for the primary coil (L1) and 40

critical. Three dials of the same design make a better-looking panel.

The R. F. tube may or may not require a negative bias, depending, of course, on the characteristics of the particular tube. From one and one-half to three volts usually will make the tube function properly. To include a "C" battery at this point, remove the lead X—XI, as shown in Fig. 1.

The set is easy to tune, as there are only two major controls, antenna dial and wave-length dial. After the detector tube is properly adjusted the setting of the rheostat can remain permanent and the volume of the output signal controlled entirely by the R. F. tube rheostat. If the coils are properly balanced the dials should read alike and then can be successfully logged. When tuning the set the dials should be rotated slowly, a degree at a time, as the stations simply drift in and out without the usual whine or whistle. If the regenerative unit is correct, over-regeneration is indicated by signal becoming mushy when too much capacity is used—that is, when the dial is advanced too far. If the set has a tendency to "pop," remove two or more turns from the secondary side of the regenerative coil as a means of correcting the fault. Another method is to move the regenerative coil from one-quarter inch to three-eighths inch away from the secondary coil.

The value of the "C" battery used in the audio circuit may be anything from four and a half volts to nine volts or more if ninety or more volts of "B" battery are used. Most audio amplifiers work better with a "C" battery, and the saving of "B" battery is considerable in the long run.

#### Wave-Length Range.

The set should ordinarily tune from 200 to 526 meters smoothly and with equal volume. However, the author found one set in several he built that was for some reason or other a little tricky on wave lengths under 300 meters—that is, it had a tendency to spill over and was difficult to balance. This tendency was corrected by making use of the Rice system of neutralization. This consists of an inductance and a neutralizing condenser. These parts are indicated in the drawing to show their location, but need only be used if difficulty is experienced on the low wave lengths. There is, however, only one chance in a hundred of their being required. The coil is composed of the same number of turns as the R. F. coil and is wound directly over the R. F. coil.

The tube in the last stage can be a 201-A if the horn type of loud speaker is used. However, if the builder intends to use a cone-type speaker, he will require a greater output voltage properly to vibrate the cone. The use of a UX171 power is suggested here as a suitable means of providing the necessary power without distorting the signal. An amperite or similar filament control device of one-half ampere capacity must be provided for this type of tube.

The choke and large condenser shown in the diagram can be used or not as the builder sees fit. With their use the output signal will be much smoother, as the heavy direct current is by-passed through the choke instead of being allowed to pass through the speaker coil.

#### Parts Required.

The following is a list of parts actually used, but there is no reason why the set would not work well if other equally suitable parts of good quality were substituted:

- One cabinet, 21 inches long and 12 inches deep.
- One baseboard, 7 by 20-inch wood.
- Brass strip, 1/2 by 1-16. See text.
- One Radion panel, 7 by 3-16 inches.
- Two variable condensers, .0005, General Instrument.
- One variable condenser, .0002, General Instrument.
- Five 201-A tubes.
- Two rheostats.
- Two Radion sockets.
- Three sockets, gang, bakelite.
- Two tubular forms, 3 by 6 inches and 3 by 3 inches Radion hard rubber.
- One grid leak, variable.
- One grid condenser, .00025.
- Three amperites and mountings, 1-A V.
- One audio transformer.
- Two resistors, .05, .25, .1 and 2.0.
- Two coupling condensers, .001.
- Twelve binding posts.
- Terminal strip, 1 1/2 by 4 by 3-16 inches.
- Terminal strip, 1 1/2 by 8 by 3-16 inches.
- Three dials.
- One filament switch.
- One pound No. 22 D. C. C.
- One-eighth pound No. 30 D. C. C.
- Necessary screws, wire for connections, etc.

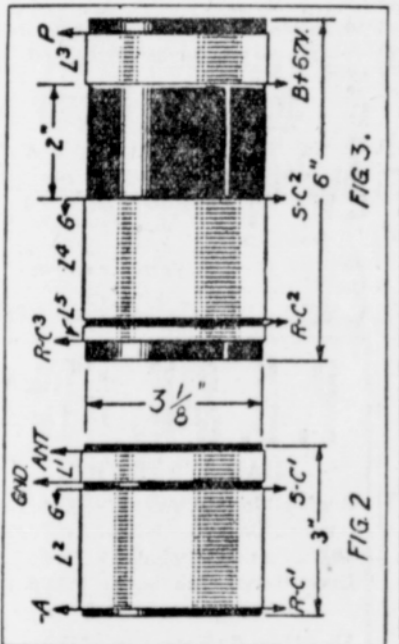

Constructional Data on Antenna and Radio-Frequency Coil of Receiver.

turns for the secondary (L2). The number of turns for this coil may vary, depending upon the length and type of aerial used. The aerial used with this set was about 75 feet in length. If a shorter aerial is used, 50 to 54 turns may be required. The spacing between the primary and secondary is not critical; from one-eighth inch to one-quarter-inch works.

#### Construction of Coils.

The coil form shown in the drawing (Fig. 3) performs a threefold duty—that of supporting the R. F. primary, the R. F. secondary and the regenerative coil. The R. F. primary coil is composed of 20 turns of No. 22 D. C. C., the R. F. secondary coil (L4) of 46 turns of No. 22 D. C. C., and the regenerative coil (L5) of 12 turns of No. 30 D. C. C. The spacing between the R. F. primary and the R. F. secondary must be two inches, or slightly more may prove even better. The regenerative coil (L5) is spaced about one-eighth inch from the secondary.

To obtain a variable condenser of .0002 capacity for the regenerator a larger condenser can be used by removing a number of the rotor plates. In this case a .00035 was used, after removing four rotor plates, which brought the capacity down to approximately .0002 mfd.

The inductance forms can be fastened directly to the baseboard with a wood screw or elevated a half inch or so on S-shaped strips of brass. One end of the S is then bolted to the form and the other end screwed to the baseboard.

For best results a good audio transformer should be used, one of not too high a ratio. One of the modern large-sized transformers should give ideal results. The resistance couplers should, of course, be of the highest grade to balance the audio transformer. A little pains taken to obtain the right resistance values is really worth while, as the builder will be amply repaid by the results obtained.

Only two vernier dials are required, as the regenerative condenser is not

## Ask for the Handy Pack P.K.



3 Handy Packs for 5¢

People who are careful of their health and strength use Wrigley's Chewing Sweets.

Because Wrigley's, besides being a delightful confection, clears the teeth of food particles and aids digestion! It removes odors of eating or smoking.

Mouth cleanliness benefits young and old. Peppermint Flavor G142

Chew it "after every meal"

Handiest thing in the house SOOTHES BURNS

Nothing more comforting than "Vaseline" Jelly. Eases pain. Hastens nature's healing. Wonderful for cuts, scratches, bruises and other little accidents.

CHESEBROUGH MFG. CO. State Street New York

Vaseline REG. U. S. PAT. OFF. PETROLEUM JELLY

A man that is young in years may be old in hours if he has lost no time.—Bacon.

## "BAYER ASPIRIN" PROVED SAFE

Take without Fear as Told in "Bayer" Package



Does not affect the Heart

Unless you see the "Bayer Cross" on package or on tablets you are not getting the genuine Bayer Aspirin proved safe by millions and prescribed by physicians over twenty-five years for

Colds Headache  
Neuritis Lumbago  
Toothache Rheumatism  
Neuralgia Pain, Pain

Each unbroken "Bayer" package contains proven directions. Handy boxes of twelve tablets cost few cents. Druggists also sell bottles of 24 and 100.

#### Mainsprings Susceptible

The mainsprings of his watch having longer refused to function early in the week, he took it to a local jeweler to whom he ventured the suggestion that a new high-grade time-piece ought to last more than a few months—it was a Christmas gift—without needing repair.

"I was surprised when the expert repair man told me more mainsprings broke during the heated season than at any other time during the year. Thunderstorms and rapid changes wreak havoc with them. It was a new one on me. We learn something every day," he confides.—Brockton Enterprise.

#### Likes His Old Bus

"I see the French are expected to make a coup d'etat."  
"Maybe so, but the ol' fiver is good enough for me."

## Decapitation Adds to Insects' Lives

At a recent session of the Academy of Science Professor Bouvier read a curious paper written by R. P. Cambouet, noted entomologist and for many years a missionary in Madagascar. The purport of the paper was to the effect that the lives of butterflies could be prolonged by cutting their heads off in such a way as to avoid a hemorrhage—an operation which, it would appear, can be performed by an expert.

Cambouet declares that he has tried the experiment successfully with eighty butterflies and that his patients—if that is the word—not only retained "all their faculties and were able to reproduce their species, but the average span of their lives in every case was prolonged by from one to two weeks."

Decapitation as a means of prolonging life! What do the many clients of Monsieur Deibler (the guillotine) think of this?—From Le Petit Parisien. (Translated for the Kansas City Star.)

#### To Study Earthquakes

Two laboratories for the scientific investigation of earthquakes are in process of erection. One is being built at Imperial university, Tokyo, Japan, and the other is being constructed at Pasadena, Calif., by the Carnegie Institution of Washington.

Ends pain in one minute CORNS

One minute—that's how quick Dr. Scholl's Zino-pads end the pain of corns. They do it safely. You risk no infection from amateur cutting, no danger from "drops" (acid). Zino-pads remove the cause—pressing or rubbing of shoes. They are thin, medicated, antiseptic, protective, healing. Get a box today at your druggist's or shoe dealer's—35c.

For Free Sample write The Scholl Mfg. Co., Chicago

Dr. Scholl's Zino-pads Put one on—the pain is gone

W. N. U., San Francisco, No. 38-1926.

#### Speaking of Cereals

"This movie is certainly mushy."  
"I think so, too. It must be a serial."—Christian Science Monitor.

## Keep in Trim!

Good Elimination Is Essential to Good Health.

THE kidneys are the blood filters. If they fail to function properly there is apt to be a retention of toxic poisons in the blood. A dull, languid feeling and, sometimes, toxic backaches, headaches, and dizziness are symptoms of this condition. Further evidence of improper kidney function is often found in burning or scanty passage of secretions. Each year more and more people are learning the value of Doan's Pills, a stimulant diuretic, in this condition. Scarcely a nook or hamlet anywhere but has many enthusiastic users. Ask your neighbor.

DOAN'S PILLS 60c

Stimulant Diuretic to the Kidneys

Foster-Milburn Co., Mfg. Chemists, Buffalo, N. Y.

KEEP YOUR SCALP Clean and Healthy WITH CUTICURA

BOILS There's quick, positive, relief in CARBOIL

At All Druggists—Vernor's Back Guarantee

EYES HURT?

For burning or sandy life, and to relieve inflammation and soreness, use Mitchell's Eye Salve, according to directions. Soothing, healing. HALL & BUCKLE, 147 Waverly Place, New York

Use Your Spare Time Until You Learn. We tell you how to start in Brown Business; universal market. Write KAY ANAGH BROS. & CO., 1232 W. Kinzie St., Chicago, Ill.

REPRESENTATIVES WANTED for large raincoat manufacturer. \$10 slickers, \$2.95. All colors; outfit free. Western Slicker Co., Dept. 400A, 1824 North Ave., Chicago.

CASH PAID FOR FALSE TEETH, GOLD bridges, crowns, and plates, diamonds, discarded jewelry, magnets, points. Cash by return mail. Florida Gold Refining Co., 21 Adams, Jacksonville, Fla.

Men are born with two eyes and one tongue that they may see twice as much as they say.—Colton.

# FISHER BODIES

GENERAL MOTORS

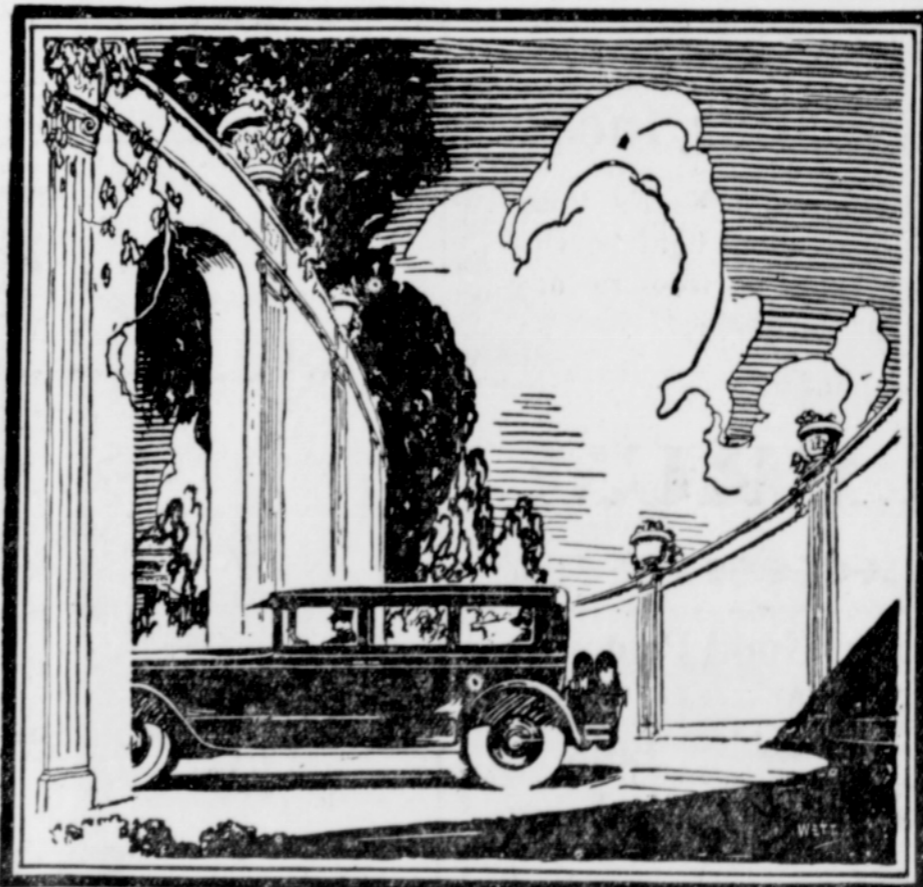

## THE INEVITABLE BODY ON THE QUALITY CARS

There could be no greater proof of Fisher quality than the selection of Bodies by Fisher for all of the leading makes of cars, in all price divisions.

Fisher Bodies have been exclusively adopted for all divisions of the General Motors Corporation, for instance.

And whether your selection be Cadillac, Buick, Chevrolet, Oakland, Oldsmobile or Pontiac, on every General Motors car you find a body with all of the inbuilt factors of safety, comfort and convenience which have

made a Body by Fisher the standard of highest quality the world over.

New products of General Motors have just been announced.

As you consider their greater merits we ask you to give particular attention to their exclusive use of Bodies by Fisher.

The latest Fisher creations set the new General Motors cars as far ahead in safety, comfort, beauty and convenience as any mechanical improvements could possibly do.

