

PAPERS ARE SIGNED

TITLE TO PANAMA CANAL NOW RESTS WITH UNITED STATES.

Agreement Transfers Property Without Reservation—Stockholders Will Now Ratify the Act of President and Director of Company—Title Is Perfect—U. S. First to Hear News.

Paris, April 25.—The Associated Press is authorized to announce that the contract by which the Panama canal passes to the United States is signed and sealed. The title to the canal is now vested in the United States. The document by which this transaction is consummated bears the signatures of President Bo and Director Richman, of the Panama canal company, who signed for the company as its responsible officers. The transfer is complete and without reservation, and the United States secures a perfect title.

This result has been quietly accomplished, and unexpectedly, as the public has been given to understand that the contract would not be executed until after the meeting of the stockholders of the Panama canal company tomorrow, at which the question of ratification would be presented. As a matter of fact, however, when the meeting takes place President Bo will announce that the sale has been completed, and, instead of asking for authority to execute a contract, it will only remain to ratify the contract of sale which the officers of the company have formally completed. Only a few of the highest officers of the company are now aware of the secret, which will not be known except by this announcement in the United States up to the time of the meeting.

It is confidently believed that the completion of the sale before this meeting will increase the vote for ratification.

RUSSIA ISSUES PAPER MONEY.

Finance Minister Says It Is Not Forced, and No Loan Is Desired.

St. Petersburg, April 25.—Russia has made a new issue of \$15,000,000 in paper currency against free gold in the State bank. At the ministry of finance it was explained that it was an ordinary issue, and in no sense was forced. Under the law paper is issuable to double the amount of gold up to \$150,000,000 gold, in excess of which paper issued must be covered round for round. In the State bank there are, in round figures, \$400,000,000 in gold, which would permit of an issue of \$550,000,000 in paper, but the paper issue at present only amounts to \$350,000,000. All sorts of figures of the cost of the war are printed abroad. The correspondent of the Associated Press is authoritatively informed that the daily expenses are averaging \$750,000, and it is estimated that a year's expenditure for the war will total \$250,000,000. To meet this there existed a free balance of \$50,000,000 by reductions in the ordinary budgets, leaving ostensibly \$135,000,000. But a portion of the latter is made up by the increased earnings of the railroads owned by the government. It being in reality a question of bookkeeping, how the balance is to be raised has not yet been determined.

ALL RETIRE AT SEVENTY YEARS.

House Committee Decides on Reform in the Civil Service.

Washington, April 23.—The house committee on reform in the civil service authorized Chairman Gillett to introduce a bill providing that on June 30, 1907, every office in the classified service of the United States held by a person who is then over 70 years old, shall become vacant, and that thereafter such offices shall become vacant when the incumbent becomes 70 years old. The committee directed Mr. Gillett to report all pending bills granting pensions to civil employes of the government to the house, with the recommendation that they lie on the table; also that the draft a bill reclassifying the clerical service of the government, with a view to providing for more frequent promotions in the smaller salaried positions.

Alaskan Fishing Season Extended.

Washington, April 25.—The secretary of commerce signed an order today rescinding the regulation which limits the duration of the salmon fishing season in Southeastern Alaska. Under the former regulation, cannerymen were prohibited from taking salmon until July 1, but the order issued today removes this restriction entirely and no date is fixed. The repeal of the old regulation was demanded by the cannerymen's association, and was also recommended by the Jordan commission.

Will Be Under Martial Law.

Niu Chwang, April 25.—Viceroy Alexieff has issued an important order declaring the Yin Kow railroad station and the native village adjoining it to be within the region under martial law. The station is the Niu Chwang, and it is a terminus of the Pekin-Shan Kai Kwan railroad and telegraph system. The order also establishes a censorship over all telegrams, the scrutiny of papers and inspection of baggage. It will go into effect tomorrow.

Protects Water Supply of Portland.

Washington, April 25.—Protection to the water supply of the city of Portland was provided by the house today when it passed a bill prohibiting trespassing on the Bull Run forest reserve. The maximum penalty for trespassing was reduced to \$500.

FIND EXCLUSION TOO SEVERE.

Senate Committee Objects to Hitt Bill Regarding Chinese.

Washington, April 23.—The general deficiency bill reported by the senate committee on appropriations carries \$11,342,146, an increase as it passed the house of \$940,525. It contains as an amendment the Hitt Chinese exclusion bill, which was accepted by the house before the bill was passed. The Hitt bill was introduced in the senate by Penrose and referred to the committee on foreign relations. In this committee the discovery, it is said, has been made that the bill will affect the introduction of Chinese coolie labor into the Panama canal zone, and to a considerable extent affect the immigration to this country of Koreans and Filipinos and the deportation from the United States, Hawaii, Porto Rico and any territory, "subject to the jurisdiction of the United States of any person held to come within the definition of the words 'Chinese persons,' and objection has been made to the far reaching effects of the bill.

When the senate committee on foreign relations began consideration today of the Chinese bill it was suggested that the bill might be of wider scope than was at first thought. Sections defining the words "Chinese person" were called to notice, and it was suggested that these might be held to relate to Filipinos, Koreans and others not intended to be included, and that the purpose of the bill might be in conflict with the existing treaties. It was late when the discovery was made, and finally the members of the committee concluded that no action should be taken on the Penrose bill in view of the fact that the Hitt amendment was reported in the deficiency bill, but that the matter might be discussed in open senate. It is understood an attempt will be made to amend the measure before the deficiency bill passes the senate.

FLEE FROM JAPANESE.

Russians are Rapidly Crossing the Yalu—Many are Drowned.

Niu Chwang, April 23.—A messenger from the Yalu river reports that the Japanese outposts are near the Russian trenches with large bodies of troops five miles distant. He also states the Russians are fleeing north across the river in overcrowded boats, losing hundreds by drowning. The messenger himself met only a few of the Japanese, but they were reported to have shown themselves in force on various occasions, afterward quickly disappearing.

The newspaper correspondents accredited to the Russian forces have left for Mukden. They bind themselves not to divulge news respecting the results of engagements, or give any information which may awaken public uneasiness.

The Russians have issued placards in Chinese explaining away the Japanese victories, detailing Russian successes, magnifying the Russian strength, and prophesying victory for Russia. The Chinese are not misled, but still believe the Japanese will conquer in Manchuria.

RUSSIA HOLDS IT BACK.

Extent of Disasters to Her Arms Cannot Be Sent Out.

Paris, April 22.—The Yinkow correspondent of the Paris Journal says he has tried repeatedly to ascertain the extent of the recent disasters to the Russian arms, and he has failed to do so because of the perfectly-organized secrecy of the Russians. In his concluding statement, he says:

"The people of France will be obliged to be satisfied with notices marked 'official' or semi-official statements sent from Harbin or Mukden many miles removed from the actual scene of war. I am close to Port Arthur, and might give the true version of many incidents, the news of which, as published, has been mere conjecture, but the Russians strictly forbid all communications of land or sea events. At the moment of sending this message, grave happenings are proceeding on the peninsula; in fact, I am told that another battle is being fiercely contested in the neighborhood of Port Arthur."

British Sympathy Much Appreciated.

St. Petersburg, April 23.—While accepting gratefully the world-wide expressions of sympathy which Russia has received at the death of Vice Admiral Makaroff and the Petropavlovsk disaster, the papers seem especially impressed with the sympathy shown by the British press, several using the text to argue on the opportuneness of the decision in favor of a Russo-British treaty. The Novisky says: "A sincere approach with Great Britain would guarantee our future development."

Skrzydloff Given Full Power.

Paris, April 23.—The correspondent of the Echo de Paris at St. Petersburg says that in the course of the audience between the emperor and Vice Admiral Skrzydloff, his majesty conferred upon the admiral full power to act at Port Arthur in accordance with the necessities of the moment. The rumor that \$10,000,000 in cash went down with the battleship Petropavlovsk, the correspondent also says, is declared to be unfounded.

Kourapatkin Waits for More Troops.

Paris, April 23.—The St. Petersburg correspondent of the Journal says friend of General Kourapatkin has received a letter from him in which the general says he intends to await the arrival of another 100,000 men before risking a battle with the Japanese.

LOSS IS MILLIONS

LARGE BUSINESS PORTION OF TORONTO DESTROYED BY FIRE.

Damage Placed at \$12,000,000 With \$8,360,000 Insurance—City Acts for Sufferers—All Public Buildings are Placed at Their Disposal—Erection of Temporary Structures Permitted.

Toronto, Ont., April 22.—The total loss by the fire which destroyed the wholesale district of Toronto last night will, according to the most conservative estimate, reach \$12,000,000, the total insurance \$8,360,000.

The area swept by the fire embraces 14 acres, and 9,000 to 10,000 persons are thrown out of employment. The work of tearing down the dangerous walls was continued until this afternoon.

The city council this afternoon placed all public buildings and the exhibition grounds at the disposal of the fire sufferers, amended the fire regulations to allow the erection of temporary structures, and appointed a committee to wait on the legislature and secure an act ordering all wires underground.

The principal warehouses of the city were reduced to ashes and nearly 250 firms were put out of business. The area covered by the fire is three blocks in length and varies from half a block to two blocks in width. Every building on Bay street, from Melinda street southward to the waterfront, was wiped out and the fire spread on Wellington and Front streets, along the waterfront from this section and the Esplanade along the waterfront from this section with Bay street for a boundary for a few hundred feet to a whole block.

From the time the fire started on the north side of Wellington street, a short distance east of Bay street, in the E. & S. Currie manufacturing plant, till it burned itself out at daybreak, there was not a moment when a shift of the wind to the northward would not have resulted in the destruction of the greater part of the city.

At a meeting of the Toronto legislature tonight, the premier and the leader of the opposition expressed sympathy with the fire sufferers, and it was decided to place a sum of money in the supplementary estimates for the benefit of the firemen's fund.

It is probable that the prorogation of the legislature, will be indefinitely delayed because of the fire. The burning of the Warwick brothers and Ruter building delays the government printing for this year.

The total number of buildings destroyed is 122; the number of firms affected is 222.

IRRIGATION WORKS FOR IDAHO.

Government Decides to Take in the Payette Valley Project.

Washington, April 22.—The government has finally decided to take up the Payette irrigation project, in Idaho, which contemplates the reclamation of 140,000 acres of land in Boise and Payette valleys, by diverting the waters of Boise river. Examinations of this project have been under way for several years, and the department is now convinced the project is feasible and can be carried out at a reasonable cost.

During the coming summer, final surveys will be made for canals and other works, and it is expected that contracts for the construction can be prepared and let by the end of the season.

The board of consulting engineers will consist of H. N. Savage, J. H. Quinton and W. H. Sanders which will soon examine the Umatilla and Malheur irrigation projects in Eastern Oregon to determine which of the two is the better adapted for government construction. The report of this board is likely to lead to the formal adoption of one or the other of these projects.

Blizzard Rages in St. Louis.

St. Louis, April 22.—A severe storm raged here today, at times assuming the proportions of a blizzard. The storm began with a sleet storm, followed by a fall of 20 degrees of temperature. Following there was a snowfall of five inches. Street traffic was impeded and trains were late. The snow prevented the games between the St. Louis and Chicago national league teams, and St. Louis and Cleveland American league teams, scheduled for today. Five to seven inches of snow fell within radius of 150 miles of St. Louis.

Flew the British Flag.

Paris, April 22.—A dispatch to the Temps from St. Petersburg says the Russian fleet, while making a reconnaissance just previous to the last attempt to blockade the entrance to the harbor at Port Arthur, sighted four ships off the Maio Tao islands flying the British flag. After the warships and the forts had sunk the vessels used by the Japanese, the Russians identified the sunken hulks as the same British ships previously seen off the islands.

Trainrobbers Get \$50,000.

Tiflis, April 22.—A train on the Trans-Caucasian railway was held up between Novosenskai and Abasha by four armed men, who entered the mail car and, after binding the officials, escaped with registered letters and valuables worth \$50,000.

HE WOULD QUIT

Viceroy Alexieff Asks the Czar to Relieve Him.

St. Petersburg, April 21.—Viceroy Alexieff has applied by telegraph to the emperor to be relieved of his position of viceroy of the Far East. It is expected that the request will be immediately granted. While no official announcement has yet been made, there is every reason to believe that the foregoing statement is correct. The immediate cause of the viceroy's application is reported to be the appointment of Vice Admiral Skrzydloff, one of Admiral Alexieff's strongest enemies and sharpest critics, as successor to the late Vice Admiral Makaroff in command of the Russian navy in the Far East.

The relieving from command of Viceroy Alexieff would not surprise intelligent observers of the Far Eastern situation, who are familiar with the gradual change in the emperor's attitude toward the viceroy and M. Bezobrovoff, who represented the military advancing element, which was anxious that Russia should remain in Manchuria. It was these two men that the Anglo-Japanese entente first lost its friends. They believed Great Britain would not go to war and that Japan could not do so. To the indignation of Japan, they succeeded in turning the policy of the empire from carrying out the treaty for the entire evacuation of Manchuria, pending further demands on China.

BIG LOSS BY FIRE.

Over \$10,000,000 Worth of Property Destroyed at Toronto.

Toronto, Ont., April 21.—Fire swept through a section of Toronto's wholesale business district tonight, causing a loss which will probably reach \$10,000,000. The fire started in a factory in Wellington street about 9 o'clock. In less than an hour the flames had spread from building to building on both sides of the street until the whole block was a mass of flames, and the fire was utterly beyond the control of the local department. Appeals were sent to every surrounding city where fire apparatus could be obtained asking for assistance. Montreal, London, Hamilton and Buffalo at once responded, but it will be hours before they can be of assistance.

It was believed at 11 o'clock that the fire was under control, but a sudden shift in the wind again fanned the flames into a roar and clouds of sparks and burning brands were carried down side streets until three entire blocks were doomed. The firemen were making a gallant fight amid the falling buildings and a mass of tangled wires, but their efforts at midnight seemed to be fruitless.

FOR RAILROAD TO ALASKA.

Victoria Endorses Project Which Will Take Trade From Seattle.

Victoria, B. C., April 20.—John Cain, of Port Angeles, Wash., addressed a crowded meeting here last night on the proposed scheme to build a railroad from the south to the north end of Vancouver island, connecting with the Port Angeles line by ferry across the Straits of Fuca and with Alaska at the north end by swift ferry steamers. He guaranteed to start building within 60 days after the subsidy is settled and complete it within two years.

The proposed line will cost \$9,000,000. The subsidy asked for is 5,000 acres per mile and \$10,000 per mile, 3 per cent inscribed stock of the province, redeemable in 40 years. The meeting endorsed the project and decided to appeal to the provincial government to take immediate action. The scheme is designed to capture the Alaska trade from the Puget sound cities and San Francisco.

Favors Offensive Tactics.

Paris, April 21.—The Figaro today publishes an interview with Vice Admiral Skrzydloff, who is now in St. Petersburg. The admiral is quoted as saying: "I believe in offensive tactics. It is necessary to push ahead and take the initiative instead of letting the enemy keep us in a state of unrest. It is essential to keep him in a state of unrest. It is necessary to invite a combat, and take chances. Any combatant who awaits his enemy is practically at his enemy's mercy. But aggressiveness does not mean imprudence."

Pacific Squadron Sails From Panama.

Washington, April 21.—The flagship New York and the cruisers Marblehead and Bennington, of the Pacific squadron, commanded by Rear Admiral Glass, have started from Panama on their cruise to the Aleutian islands by the way of Honolulu. They first will proceed up the coast to Acapulco, whence they will sail to the Hawaiian islands, a distance of about 3,300 miles. The next run will be from Honolulu to Unalaska, in the Aleutian group, a distance of about 2,000 miles.

Russia Only Protecting Herself.

St. Petersburg, April 21.—The foreign office explains that the notice served by Russia regarding newspaper correspondents employing wireless telegraphy is a natural measure of self-protection against possible communication with the enemy. It would be possible from land or sea for correspondents using wireless telegraphy to communicate with the enemy. If an actual case should arise, however, it will be judged on its merits.

Denies She Has a Submarine Boat.

London, April 21.—Captain Kabachi the new Japanese attaché, who has arrived in London from Japan, denies positively that there are any submarine vessels in the Japanese navy.



Adjustable Wagon Seat.

The illustration shows a handy wagon seat which is comparatively easy to construct. Take a two-inch board six inches wide, round the ends and cut slots in each end as shown, so that it will go between the stakes of the wagon. Fasten a board a foot wide and three feet long in the center of the first board as shown in the cut. Then take an old seat, from some old machine, of form one if you are handy with tools and fasten it as shown.

A good home-made seat could be formed of inch boards mounted to a place of tough hickory and bolted to the boards, as shown, with a brace of iron at the back. Such a seat would

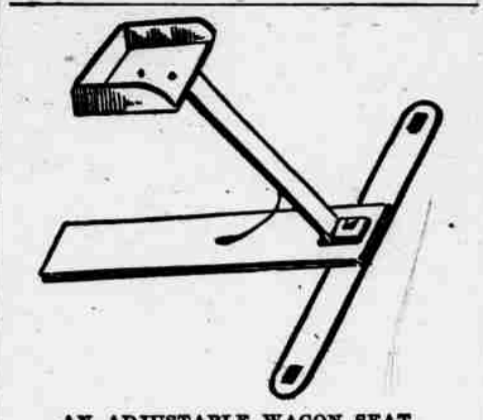

AN ADJUSTABLE WAGON SEAT.

be very handy to use when doing rough hauling, while it might not be sufficiently attractive to use on the road. It is comfortable, which is the main point to be considered.

Making Draft Horses.

There is one thing that the man who is trying to raise big horses should not overlook—and that is plenty of food for the colts. A draft-bred colt that has not enough to eat will not make a draft horse—he will be a chunk of some grade, not heavy enough for a draft horse. Some people claim that draft colts will not require any more feed than colts of a lighter breed. That is an error. They do require more, but not so much in proportion to their size as does the light horse, because they are of a quiet disposition and put more of their feed into growth and less into exercise or nervous fretting than the light horse. But no big horse will be produced if the feed is lacking. Give the colts enough to keep them growing, and they will pay a good price for all they eat when the time comes to sell them. At a sale in Ohio last week draft geldings coming 4 years old sold to feeders at \$200 to \$285 a head. When feeders can afford to pay such prices for horses to fatten for market there is nothing wrong with the draft horse business. But there were no stunted colts in the bunch that sold for these figures.

Three Horses to a Wagon.

Here's a device for hitching three horses to a wagon. The method illustrated substitutes two wagon poles for one, the middle horse between the two

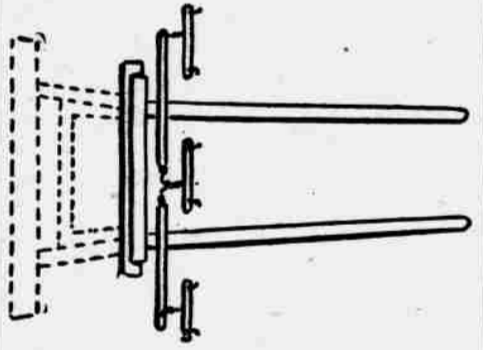

THREE-HORSE DEVICE.

poles or shafts. There are two neck-yokes and a triple evener. The middle horse has one-third of each double-tree, making two-thirds of both, while each outside horse has two-thirds of the evener he is hitched to.

Sanitary Straw Hog House.

The best hoghouse on earth is made by setting two rows of fence posts one foot in ground and four feet apart one way, and one post length apart, the other way, so posts may be used for stringers on top. Put cord wood crosswise on top of stringers and build straw pile over all, leaving hole in one end big enough for a hog to enter. They will all follow in and complete interior arrangement of house to suit their hogish artistic taste.

This house will always be dry and comfortable and will save many a heated argument with the hired man about cleaning out and bedding the hogs. Hogs can be fed out of doors, or a board feeding room may be built at one end of stack with door between. In summer, pull out posts and burn straw hoghouse, haul out refuse and build new each year. Then you will have healthy hogs, avoid mange and many other parasites. I winter 30 hogs every year in this kind of a house.—A. A. Andrews, North Dakota.

Uses of Canned Eggs.

The use of refrigerator eggs has become so widespread as to cover a greater part of the habitable earth. There has been a great trade in canned eggs recently. Large quantities of canned eggs are bought by confectioners, and they are also used in the manufacture of linen. Several countries supply eggs for such purposes, but the supply is not equal to the demand. Large importations of canned eggs come from Russia, Germany and

Denmark. These usually arrive in large packages and are packed in some unknown preservative and are hermetically sealed. The air is excluded in some manner, as it will not do to heat them as in canning fruit, as that would destroy the value of the product. Science is still doing wonders, and we may be able to have full control of the egg trade of the whole world in the near future. Great strides have already been taken, but there is room for more improvement.

Feeding Oats in the Sheaf.

One of the first things I learned when a boy was that feeding sheaf oats to horses was wasteful. However, I had to do it last fall and I now wish I had saved a portion of my thrashing bill that way. Several years ago I read of a certain farmer condemning a cow because she leaked her milk, while he had other cows that did not pay their keep, although they did not leak their milk, while the first cow paid well in spite of her leakage. Now, in the case of my horses, I have known them to pass oats with their manure in so perfect a state that they would grow, and no scheme of driving nails in the bottom of their feed boxes, putting in stones or having their teeth flatted by a horse doctor had any effect on them. But, lo! when I fed them sheaf oats, not the first vestige of an oat could be seen in their manure. Now, what difference does it make where or how the oats are wasted? And if a few pigs could have access to the stable when the horses were out in the field, it seems to me that sheaf oats would have the best end of the argument.—Farm, Stock and Home.

Removing Warts from Horses.

Take about four leaves of strong cured tobacco, place them in a vessel, pour about one-half gallon of water over them, place on the fire, letting it boil down to a strong juice, and apply to the wart. Always pick the wart so as to make it bleed before the application, that it may strike into the fungous growth. A few applications will soon do the work; gradually the enlargement will decrease and disappear as if by magic. As an evidence of its efficacy, some years ago a horse that we drove had a bleeding wart on his back that the lines kept continually bleeding. It was about the size of a walnut, with a neck about the size of one's index finger. I would occasionally sprinkle a few crumbs of tobacco on it from my pocket, and the wart went away. I have removed warts as large as a pint cup from horses' legs by taking the tobacco leaves, dipping them in hot water and binding them to the affected part. Try it and you will be rewarded for your trouble.—Exchange.

Geese on Lowlands.

Geese are extremely hardy and long lived. They thrive on low-lying lands which would not be suitable for fowls. Old pasture is best suited to their requirements, as they crop the grass very short, and would likely destroy the roots of newly sown grass. They must be afforded liberty and lots of grassy range. They are very coarse feeders and will eat nearly anything in the shape of green food. Although it is desirable to hatch early, it is not always advisable, as it depends upon the climate and location. Goslings need grass, and do not thrive unless green food is supplied when they cannot get range.

Importance of the Hens.

It is estimated that the production of chickens in the United States last year reached 3,350,000,000, and of eggs thirteen billion. The total value was \$290,000,000. The true importance of the poultry business will, however, be better appreciated by the following comparisons: Our annual wool clip is about \$28,000,000; sheep, \$65,000,000; swine, \$180,000,000; cotton, \$250,000,000; wheat, \$227,000,000; tobacco, \$43,000,000; potatoes, \$80,000,000; barley, \$30,000,000; oats, \$200,000,000.

Our Butter States.

The manufacture and consumption of butter in the United States is constantly growing. In 1870 we made 515,000,000 pounds, while thirty years later, in 1900, we made nearly three times as much—1,492,000,000 pounds. Of the great butter-producing States Iowa comes first, New York second, and the others in the following order: Pennsylvania, Wisconsin, Ohio, Illinois, Minnesota, Michigan, Kansas, Indiana.

Farm Notes.

An important item in stock feeding is regularity. Long feet are frequently the cause of lameness in horses.

It is a waste of feed to give more than an animal can digest.

With all stock, food may be wasted by giving too much or too little.

Sheep, when being fattened, should have protection from wet and cold.

With all stock, there is no single feed that possesses only good qualities.

Early pampering should be avoided if mature and healthy development is desired.

The sheep raiser who is not progressive cannot expect to attain perfection in his calling.

Labor, even on the farm, is most effective when directed by intelligence and thought.

To injudicious feeding may be credited a large amount of the fatality among hogs.

The brood sow should have plenty of nourishing food such as will cause a healthy growth without too much fat.

Variety of live stock on a farm quite as much as variety of cropping is a source of wealth accumulation in the holding.